

GTC **CONNECT**



ACCESS2000 Network Controller & Wireless Gateway Operational Guide

TABLE OF CONTENTS

- Included in Package 3
- ACCESS2000 Network Requirements 4
- Head & Base 6
- Mounting & Installation 7
- Setup Bluetooth Router 10
- Gateway Reset Procedure 11
- Product Interface 15
- Power 15
- Environmental 15
- Federal Communications Commission (FCC) Interference Statement 15
- RF Exposure Warning 16

I. INCLUDED IN PACKAGE

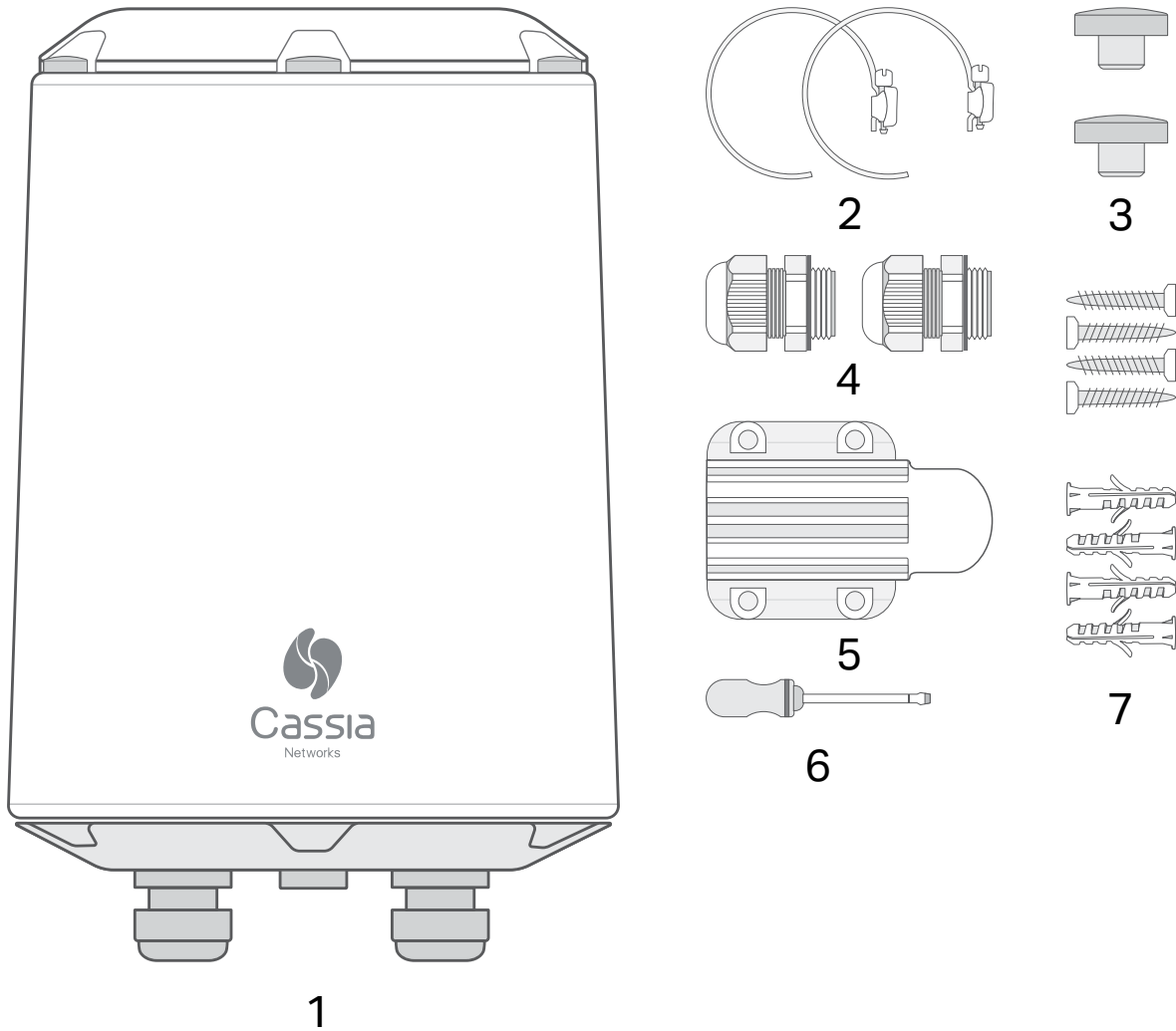

- 1. ACCESS2000 Router (1)
- 2. Pole Mounting Straps (2)
- 3. Extra Top Screw Covers (2)
- 4. Cable Glands (2)
- 5. Mounting Bracket (1)
- 6. Slotted Screwdriver (1)*
- 7. Anchors with Screws (2*4)

*Only for removing the Ethernet cable (depress the plastic release tab)

II. ACCESS2000 NETWORK REQUIREMENTS

Supported Network Configurations

ACCESS2000 supports deployment using **either a wired PoE Ethernet connection or Wi-Fi**, depending on the installation environment.

CTC recommends a hardwired Ethernet connection to the gateway whenever possible. A wired connection offers the greatest stability and the lowest risk of RF interference. In some facilities, however, network restrictions may prevent a wired connection.

Wi-Fi connectivity to the gateway is best utilized in places where the network has security policies in place that will impact the functionality of the gateway, such as VPN, NTP, or other network protocols required to connect to or manage the gateway.

Ethernet (PoE) Requirements

- **Power:** IEEE 802.3af or 802.3at PoE
- **Network Interface:** 10/100/1000 Mbps Ethernet
- **Backhaul:** Wired Ethernet connection to the customer's LAN

Wi-Fi Requirements

- **Wi-Fi:** Customer-provided wireless network
(2.4 GHz / 5 GHz, as supported by device firmware)
- **Security:** WPA2/WPA3 (per device configuration options)
- **Signal Quality:** Installation location must ensure stable signal strength and low interference

General Network Requirements

- **IP Addressing:** DHCP or static IP (customer-managed)
- **Internet Access:** Required for CTC Connect communication, data upload, and firmware updates

ACCESS2000 should be installed on a **stable, business-class network** with sufficient uptime, bandwidth, and administrative controls.

CTC recommends a hardwired Ethernet connection to the gateway whenever possible. A wired connection offers the greatest stability and the lowest risk of RF interference. In some facilities, however, network restrictions may prevent a wired connection.

Wi-Fi connectivity to the gateway is best utilized in places where the network has security policies in place that will impact the functionality of the gateway, such as VPN, NTP, or other network protocols required to connect to or manage the gateway.

Firewall & Security Requirements

The customer is responsible for allowing required outbound traffic:

- Outbound HTTPS (TCP 443) to CTC Connect services
- Outbound NTP (UDP 123) to connect to Global NTP servers
- DNS resolution enabled

Unsupported or Customer-Managed Configurations

The following configurations may be technically possible, but are **not supported under CTC Connect Support**. CTC does not provide configuration guidance, documentation, or troubleshooting for these scenarios:

- Cellular routers, cellular modems, LTE/5G gateways, or hotspots used as network backhaul
- Wi-Fi networks with captive portals, user-based authentication, splash pages, or rotating credentials
- VPN tunnels, private APNs, or secure overlay networks
- Customer-managed firewall rules, deep packet inspection, proxying, or traffic shaping
- MQTT broker hosting, configuration, or message routing infrastructure
- Network policies that block, throttle, proxy, or intermittently disrupt required outbound traffic

Any connectivity, latency, reliability, or data-loss issues caused by these configurations are outside the scope of CTC Connect Support.

Remote Management of Gateways

- Internet connection to include the industrial network of the facility where the equipment is installed or cellular (such as Teltonika RUTM20) or satellite (such as Starlink).
- Software VPN connection to securely connect to the local network where the gateway is installed. VPN connection will require the use of a static IP address for the cellular connection to the gateway or the use of DYNDNS (Dynamic DNS). Please note that the use of a static IP address is preferred for stability.

Note: Industrial networks are often secured by a corporate firewall which will cause challenges in being able to VPN to the gateway and/or there may be port blocking rules put in place which will limit TCP/UDP connections to the gateway or internet. **When installing CTC Connect Systems in an industrial network, it is important to have the plant network administrative team involved.**

III. HEAD & BASE

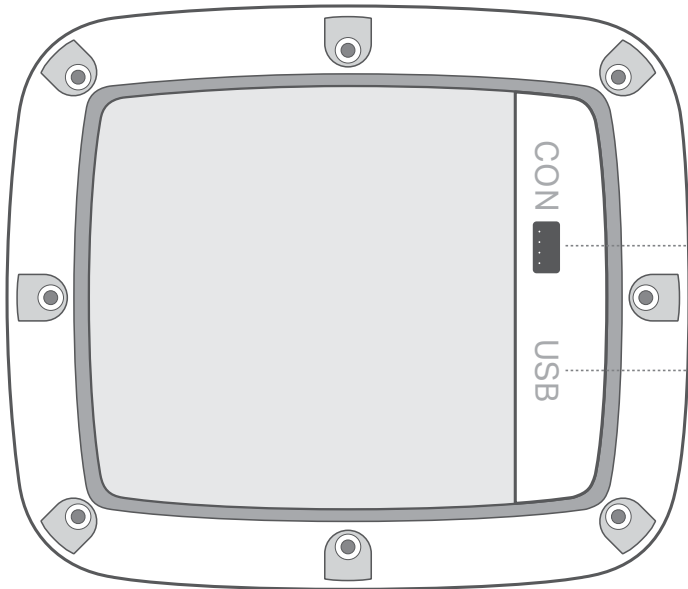

- Not used
- USB 2.0

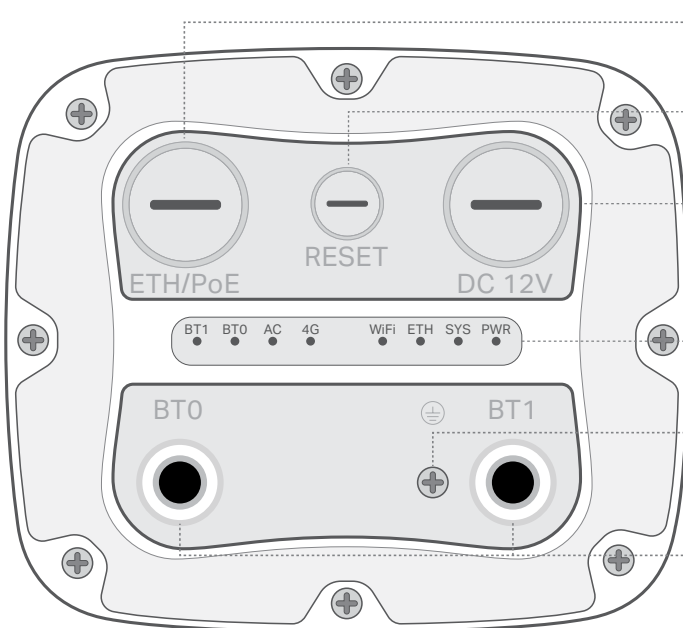

- Ethernet and PoE
- Reset
- 12V DC
- LED Lights
- Ground
- Opt. external Bluetooth antenna connectors

IV. MOUNTING & INSTALLATION

Note: DO NOT mount the access point inside a metal enclosure.

Metal enclosures will significantly attenuate RF signals and can severely degrade wireless performance, range, and reliability.

Mounting the access point inside a non-metallic enclosure is also not recommended. The impact on signal strength and overall system performance is unknown and may vary based on enclosure material, thickness, size, and internal layout. Performance degradation is especially likely if additional electronics or hardware are installed inside the enclosure alongside the access point.

For optimal wireless performance, the access point should be mounted in an open environment with a clear RF path to the sensors.

1. Mount the ACCESS2000 mounting bracket in a vertical orientation onto a wall or pole with the supplied mounting kit

NOTE: The side of the mounting bracket facing the wall and pole is sharp. Please don't hurt your hands.

Wall Mount

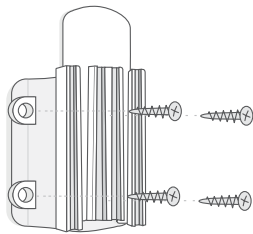

Pole Mount

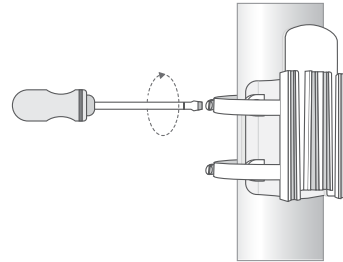

2. Slide ACCESS2000 down on the ACCESS2000 mounting bracket

Wall Mount

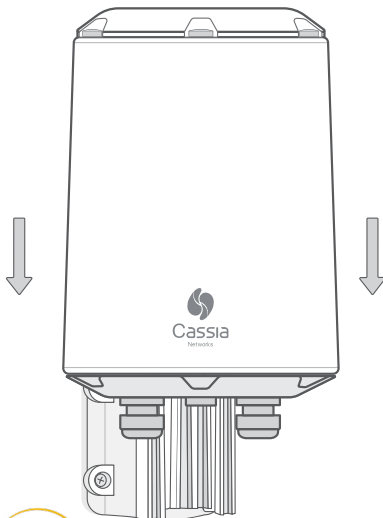

Pole Mount

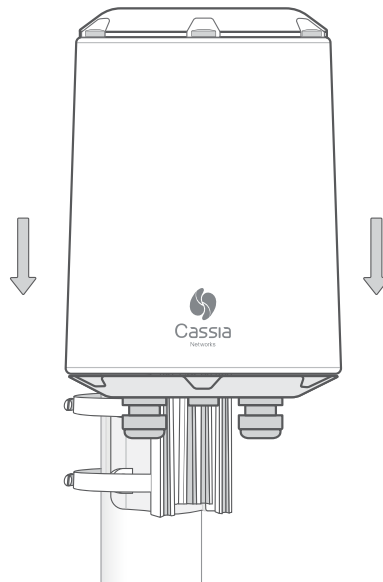

3. Connect Ethernet cable and PoE

Remove the ETH/PoE plug (M22X1.5), pass the Ethernet cable through the cable gland, insert the RJ-45 connector into the Ethernet port of ACCESS2000, and tighten the cable gland in the order of a, b, c. The torque of step c should be less than the torque of step a.

NOTE: When removing the cable gland, please follow the order of c, b, a. Otherwise ACCESS2000 will be damaged.

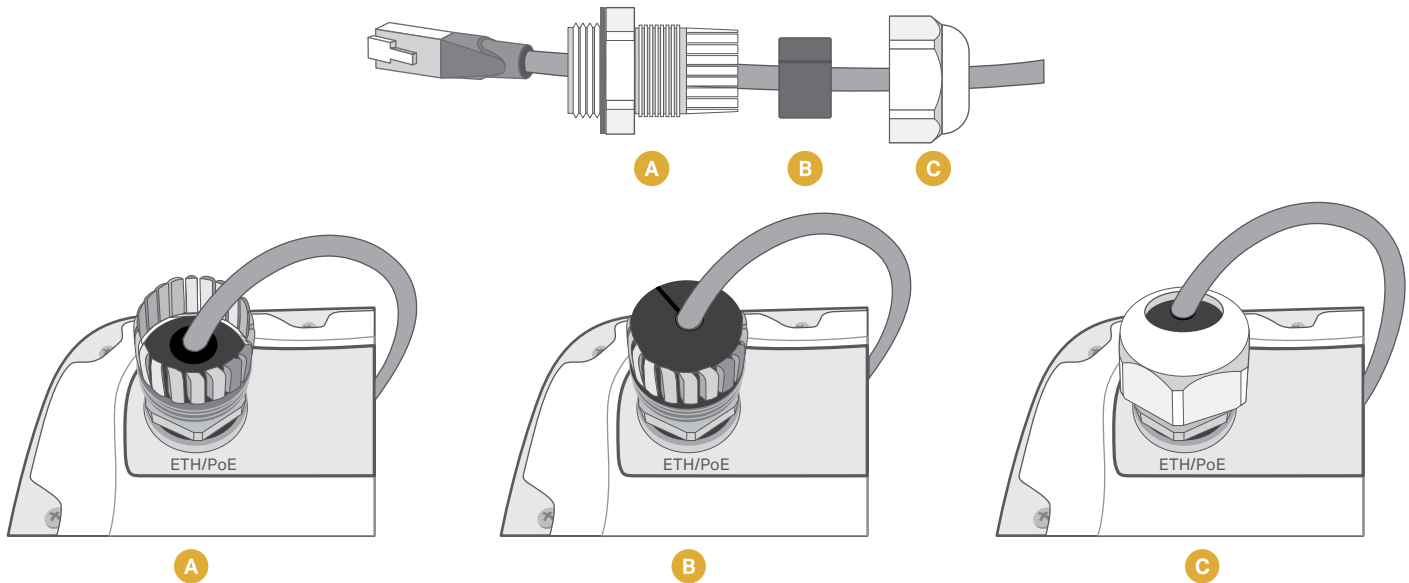

NOTE: In order to remove the Ethernet cable once it's been installed, please use the supplied screwdriver in the ACCESS2000 box or a small pointed tool of your choosing to depress the plastic release tab on the cable. See image below.

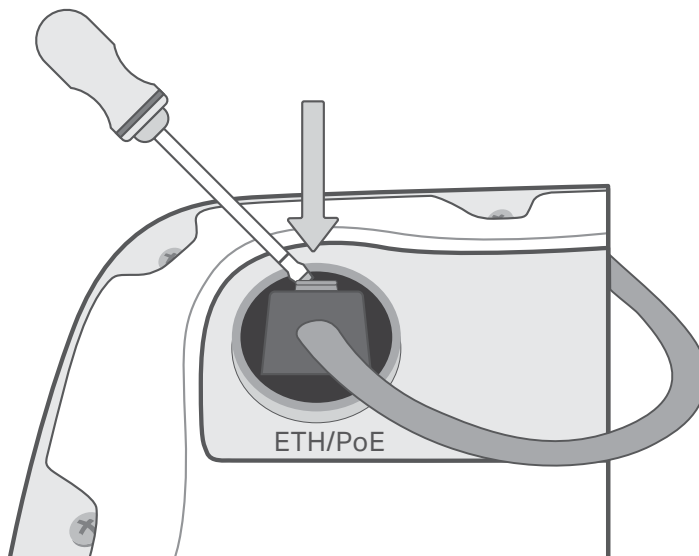

4. Connect 12V DC power cable and cable gland to ACCESS2000 in the same way as step 4

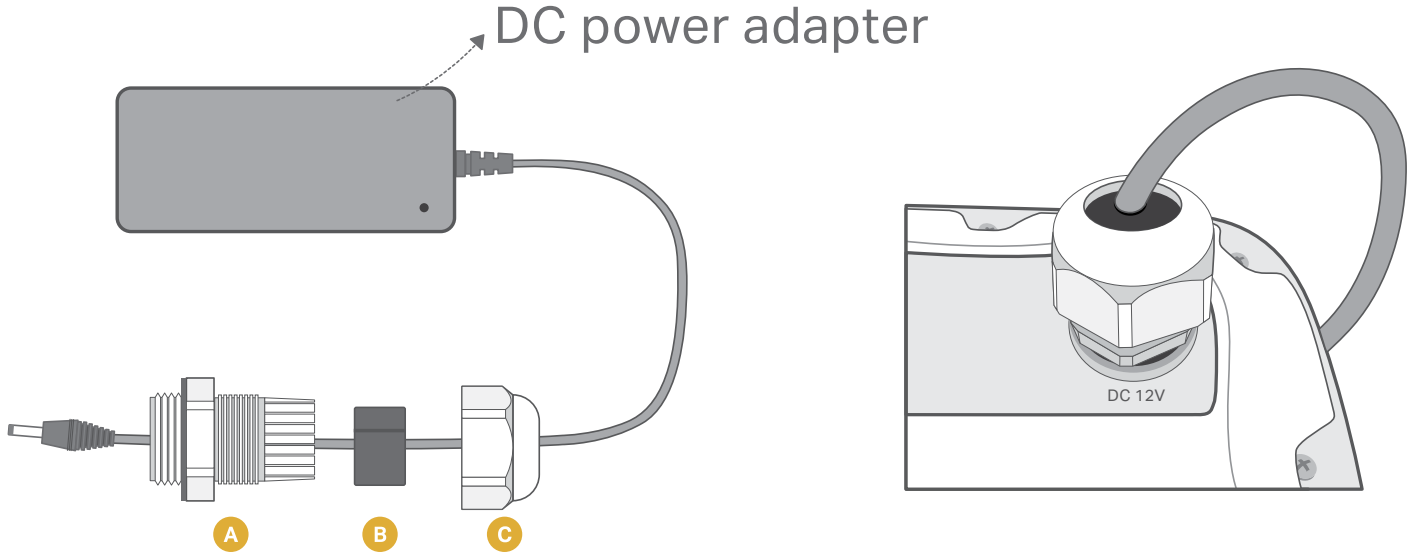

5. For outdoor ACCESS2000 installations, please connect the ground cable to ensure ACCESS2000's safety

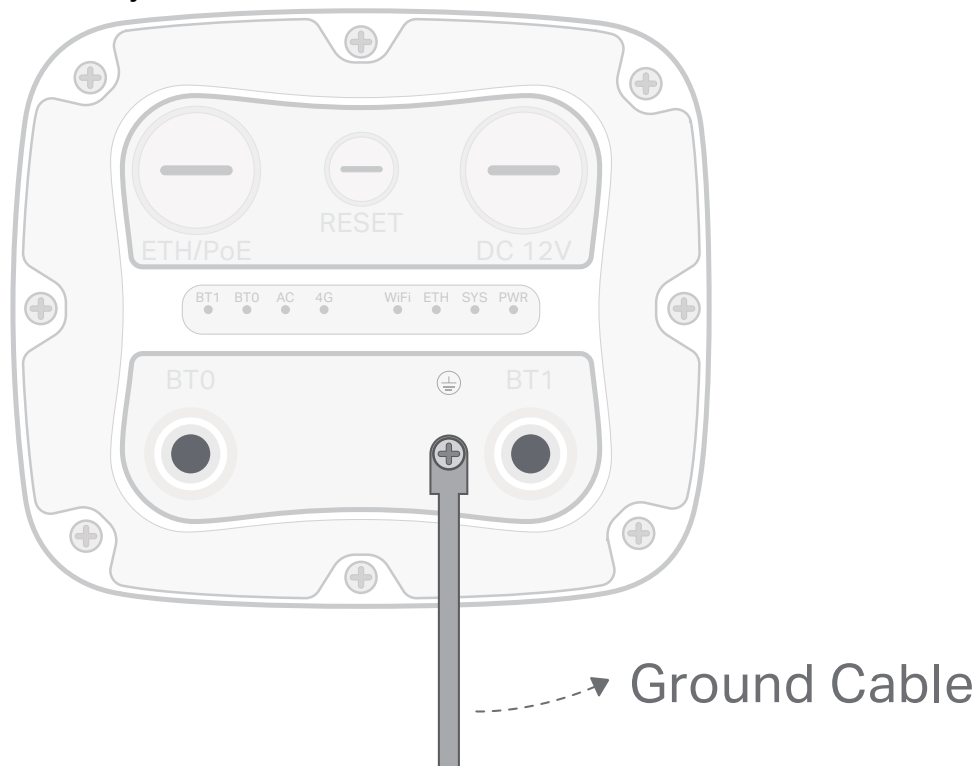

V. SETUP BLUETOOTH ROUTER

1. Power On the Gateway

Using either:

- a. **Power over Ethernet (PoE)**
- b. **A 12V power adapter**

Allow approximately 3 minutes for the gateway to fully boot.

2. Connect to the Gateway WiFi

Once powered on, the gateway will broadcast a Wi-Fi network.

From your computer or laptop, connect to the network named **cassia-XXXXXX** (the last six characters of the gateway's MAC address). This can be found on the sticker on the box as well as on the bottom of the Gateway.

The default password of the Wi-Fi hotspot is the same as the SSID.

3. Open the Configuration Page

After connecting to the gateway's WiFi, open a web browser and navigate to **http://192.168.40.1**

The default username is: admin

The default password is: 7939Rae!

4. Identify the Gateway IP Address

Navigate to the Status tab

You will see multiple IP addresses listed:

- a. **ETH IP** - Use this if the gateway is connected via Ethernet
- b. **WLAN IP** - Use this if the gateway is connected via WiFi

Make note of the IP address relevant to your connection method.

5. Configure Wi-Fi (Optional)

Skip this step if you are using Ethernet.

- a. Go to the **Basic** tab
- b. Locate **Connection Priority** near the top of the page
- c. Set the connection priority to **WiFi**
- d. Scroll down to the **Wi-Fi Client** section
- e. Enable the Wi-Fi Client
- f. Enter your wireless network credentials
- g. Click **Apply** to save the configuration

The gateway will now connect to your wireless network.

6. Reconnect to Your Network

Disconnect from the gateway's Wi-Fi (cassia-XXXXXX).

Reconnect your computer to your normal network (Ethernet or WiFi).



7. Access the Gateway User Interface

Open a web browser and navigate to **http://<gateway-ip>:60001**

Replace <gateway-ip> with the **ETH IP** or **WLAN IP** identified in Step 4.

The gateway user interface should now load.

As part of your first login, you will be prompted to change the default password. If you forget your password or can't find the Wi-Fi hotspot, please reset the router to default settings by pressing and holding the reset button for 10 seconds.

VI. GATEWAY RESET PROCEDURE

If the gateway factory reset procedure has been performed, the initial setup as performed by CTC must be verified. Use the guide below to verify or configure the gateway to the parameters required to run the CTC Connect Software on the ACCESS2000 Gateway.

1. Basic Tab

- Check to make sure the gateway is in Standalone Mode
- Check to make sure the Connection Priority is set to match their network configuration: wired/wireless

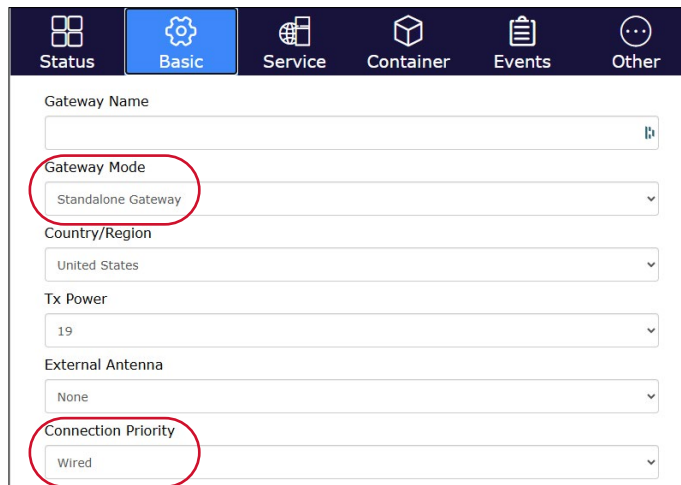

The screenshot shows the 'Basic' configuration tab of the gateway interface. The 'Gateway Mode' dropdown menu is set to 'Standalone Gateway' and is circled in red. The 'Connection Priority' dropdown menu is set to 'Wired' and is also circled in red. Other visible settings include 'Gateway Name', 'Country/Region' (United States), 'Tx Power' (19), and 'External Antenna' (None).

If you change any settings on this screen, hit apply at the bottom of the page.

- c. Check to make sure the network is configured properly: wired/wireless
 - In order for the CTC software to access the Internet, a gateway and DNS are required. If the IP Allocation is set for DHCP, the network will/should provide that information. If the IP allocation is set for static, this must be entered manually.

Wired

IP Allocation
DHCP

DNS1

DNS2

Hotspot(Setup Only)

Enable

SSID
cassia-E5BCA4 Hide

Password

IP
192.168.40.1

Netmask
255.255.255.0

Wi-Fi Client

Wireless Network
Enable

SSID

SSID length should be 1 - 32 !

Security Mode
WPA2-PSK

Password

Password length should be 8 - 63 !

IP Allocation
DHCP

DNS1

DNS2

Add Secondary Wi-Fi
No

Cellular Modem

USB Modem Type
None

Apply

2. Service Tab

This is not used for CTC purposes and can be skipped.

3. Container Tab

- a. Check to make sure the container is loaded, if it is not, you will need to re-add it.
- b. If loaded it should also be running.
- c. Double check to make sure the USB drive is seen and being used.

Operating System	Ubuntu 20.04 LTS
Container Status	running
Container Version	2.0.1
CPU Usage	8.00%
Memory Usage	1.98%
Storage Usage	1.11GB / 2.28GB
USB Storage Usage	144KB / 14.45GB
Transmit Rate	0KBps
Transmit Bytes	800KB
Receive Rate	0KBps
Receive Bytes	1.02MB

Installed APPs (1)			
#	Name	Version	Action
1	CTC_Connect	2.1	<button>Del</button>

To check if the container is running, scroll down to Programs in operation and you will see the various applications in the container running.

Programs in operation		
USER	PID	COMMAND
root	1	/sbin/init
root	57	/usr/sbin/cron -f
messa	58	/usr/bin/dbus-daemon --system --nofork --nopidfile
syslo	61	/usr/sbin/rsyslogd -n -iNONE
root	91	sshd: /usr/sbin/sshd -D [listener] 0 of 10-100 startups
root	199	/usr/lib/bluetooth/bluetoothd -d -E

Container Configuration:
Check the following settings
Enable Local SSH Login: ON
Protocol: TCP
Port: 60001
Enable USB Access: On

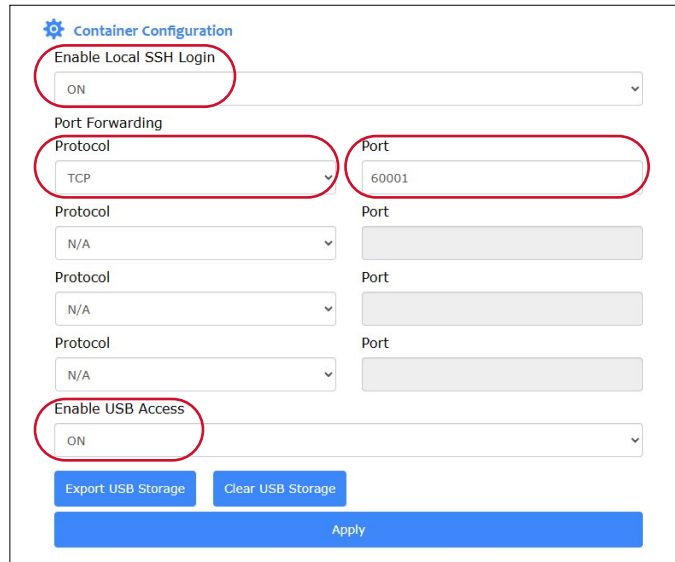

If you make any changes on this page, hit apply and reset the container.

4. **Events Tab**

This is not used for CTC purposes and can be skipped.

5. **Other Tab**

a. Check the Time Configuration section.

- Time zone should be set to the local Time Zone or Universal Time UTC
- NTP Server 1: 0.pool.ntp.org
- NTP Server 2: 1.pool.ntp.org

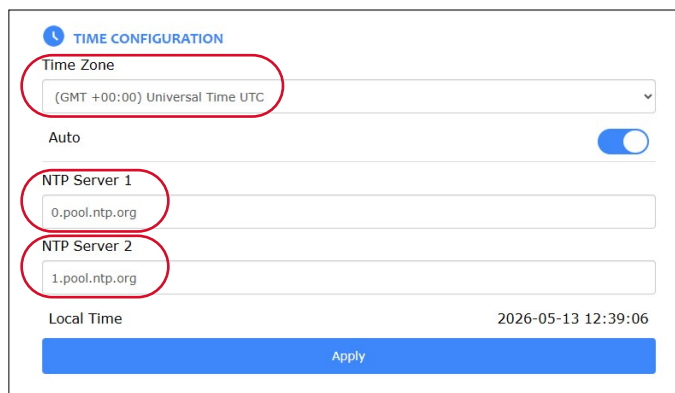

If you change any settings on this screen, hit apply in that section.

6. Gateway Restart

After making any major change, it is best to reboot the gateway to ensure those changes take effect.

In the other tab, scroll all the way to the bottom, under Actions, hit the Reboot Button.

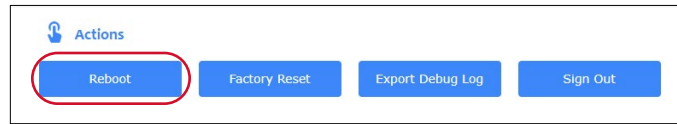

VII. PRODUCT INTERFACE

Bluetooth Low Energy: 4.0/4.1/4.2/5.0

Wi-Fi: 802.11 a/b/g/n/ac, 2.4GHz and 5GHz ISM band Ethernet: 10/100 Base-T

USB 2.0: supports USB cellular modem

Opt. external Bluetooth antenna connectors: 50 Ω N type female connector

Reset button: Factory reset. Please remove the reset plug (M12X1.5) first

LED lights: BT/AC/4G/Wi-Fi/Ethernet/System/Power

VIII. POWER

Power over Ethernet: 802.3af/at compliant source Optional: 12V DC power adapter [1]

NOTE: Please don't use two power sources at the same time

IX. ENVIRONMENTAL

Operating temperature: -40°C to +65°C (-40°F to +149°F)

Humidity: 0% to 90% non-condensing

Storage and transportation temperature: -50°C to +70°C (-58°F to +158°F)

Wind resistance: up to 85-MPH sustained winds & 135-MPH gusts

IP rating: IP66

[1] Connector type: Interior diameter 2.5 mm / outside diameter 5.5 mm, center +v / outer -v

Output voltage: 12V

Output power: Equal or larger than 12 W

X. FEDERAL COMMUNICATIONS COMMISSION (FCC) INTERFERENCE STATEMENT

This equipment has been tested and found to comply with the limits for a Class B digital device, pursuant to part 15 of the FCC Rules. These limits are designed to provide reasonable protection against harmful interference in a residential installation. This equipment generates, uses and can radiate radio frequency energy and, if not installed and used in accordance with

the instructions, may cause harmful interference to radio communications.

However, there is no guarantee that interference will not occur in a particular installation. If this equipment does cause harmful interference to radio or television reception, which can be determined by turning the equipment off and on, the user is encouraged to try to correct the interference by one or more of the following measures:

- Reorient or relocate the receiving antenna.
- Increase the separation between the equipment and receiver.
- Connect the equipment into an outlet on a circuit different from that to which the receiver is connected.
- Consult the dealer or an experienced radio/TV technician for help.

NOTE: Any changes or modifications not expressly approved by the party responsible for compliance could void the user’s authority to operate the equipment.

XI. RF EXPOSURE WARNING

This equipment must be installed and operated in accordance with provided instructions and the antenna(s) used for this transmitter must be installed to provide a separation distance of at least 20 cm from all persons and must not be co-located or operating in conjunction with any other antenna or transmitter.

End-users and installers must be provided with antenna installation instructions and transmitter operating conditions for satisfying RF exposure compliance.

Need Additional Technical Support?

Need additional technical support for issues or questions about the Connect Wireless ecosystem?

Scan the QR code or use the hyperlink to access our convenient web form to submit your request online at any time.

CTC’s experienced support team will review your inquiry and work quickly to resolve your issues.



scan QR code or

**CLICK HERE FOR
SUPPORT REQUEST FORM**

The Bluetooth® word mark and logos are registered trademarks owned by Bluetooth SIG, Inc. and any use of such marks by Connection Technology Center, Inc. (CTC) is under license. Other trademarks and trade names are those of their respective owners.

